

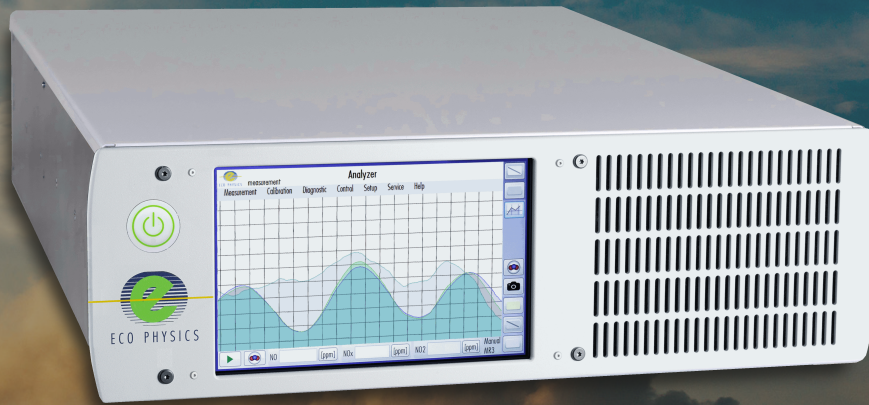

ECO PHYSICS nCLD EL²

APPLICATION EXAMPLES

- Gas manufacturers
- Manufacturers of gas turbines
- Certification and calibration
- DeNOx plants
- Stack gas measurement
- Petrol industry
- Research and development



The nCLD EL² is the next generation in two-channel NO/NO₂/NO_x measurement. Unique in speed and precision, the nCLD EL² allows the continuous measurement of concentrations in the range of parts per million. Its new and intuitive user interface individually displays and connects to other instruments' data.

Measurement of:

- NO
- NO₂
- NO_x

nCLD - A New Generation

The nCLD EL² includes everything that is needed for measuring NO, NO₂ and NO_x in unpreconditioned gas samples. The fully revised detector-block, the enhanced gas flow paths and the improved pressure as well as temperature independence allow for even lower detection limits. Overall stability and reliability are lifted to a new level. The integrated hot tubing enables the instrument to analyze hot and moist sources without external gas preconditioning unit, allowing highly precise analysis. The calibration of the unit runs quickly and automatically, with all necessary data stored and available anywhere and at any time.

User Friendliness

The new touch sensitive graphical user interface enables the user to individually adjust the instrument operation and data management according to his/ her needs and applications. The bright 7" monitor gives a clear overview and allows numerical and graphical display of values. Multiple digital in- and outputs guarantee a maximal connectivity for your remote operation, control and maintenance of the nCLD EL², ensuring unsurpassed precision and reliability.

Compact, Modular and Intelligent!

The nCLD EL² is manufactured in a new compact layout, in which each essential component hosts its own CPU and interacts with other CPUs by BUS-communication. This assembly increases accessibility and serviceability by reducing wiring and piping. The measurement principle will conform to the standard method for NO_x-detection in stationary source emissions (EN15267).

- Rapid system integration and rack mounting
- Compact and modular design
- Virtually maintenance free even in continuous operation
- Four freely selectable measuring ranges

Graphical user interface for individual analyzer operation and data management

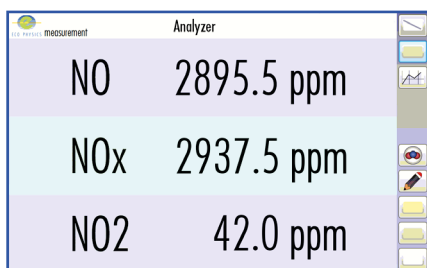

Measurably better

SPECIFICATIONS

nCLD EL²

Analyzer type	two chamber CLD with cooled PMT for measurement of NO, NO ₂ and NO _x	Supply voltage	100 - 240 V / 50 - 60 Hz
Measuring ranges	four freely selectable ranges from 5 ppm - 5'000 ppm	Interface	USB(3x), HDMI, Bluetooth, RS232 (w/o 9pin connector), LAN, WLAN
Min. detectable concentration*	0.12 ppm	Dimensions	height: 133 mm (5¼") width: 450 mm (19") with molding: 495 mm depth: 540 mm (21.2")
Noise at zero point (1σ)*	0.06 ppm	Weight	23 kg (51 lb)
Lag time	<3 sec	Delivery includes	nCLD EL ² analyzer, power cable, FTDI-RS232-USB cable, USB-LAN adapter
Rise time (0 - 90%)	<1 sec	Standard	nCLD 822 Mh · M - metal converter · h - hot tubing
Temperature range	0 - 40 °C (non-freezing)	Options	· USB-RS232 9pin connector · 0 - 10 V · 4 - 20 mA into 500 Ω max.
Humidity tolerance	5 - 95% rel. h (non-condensing, ambient air and sample gas)	Analog output (External Box)	
Sample flow rate	1.0 l/min		
Input pressure	600 - 1'200 mbar abs.		
Dry air use for O ₃ generator	internally generated (no external supply gas required)		
Power required	350 VA (incl. membrane pump and ozone scrubber)		

© ECO PHYSICS AG, Switzerland 2020 - 1 / 2

FLOW DIAGRAM

*Depending on filter setting
Connectivity properties are country-specific
ECO PHYSICS reserves the right to change these specifications without notice.

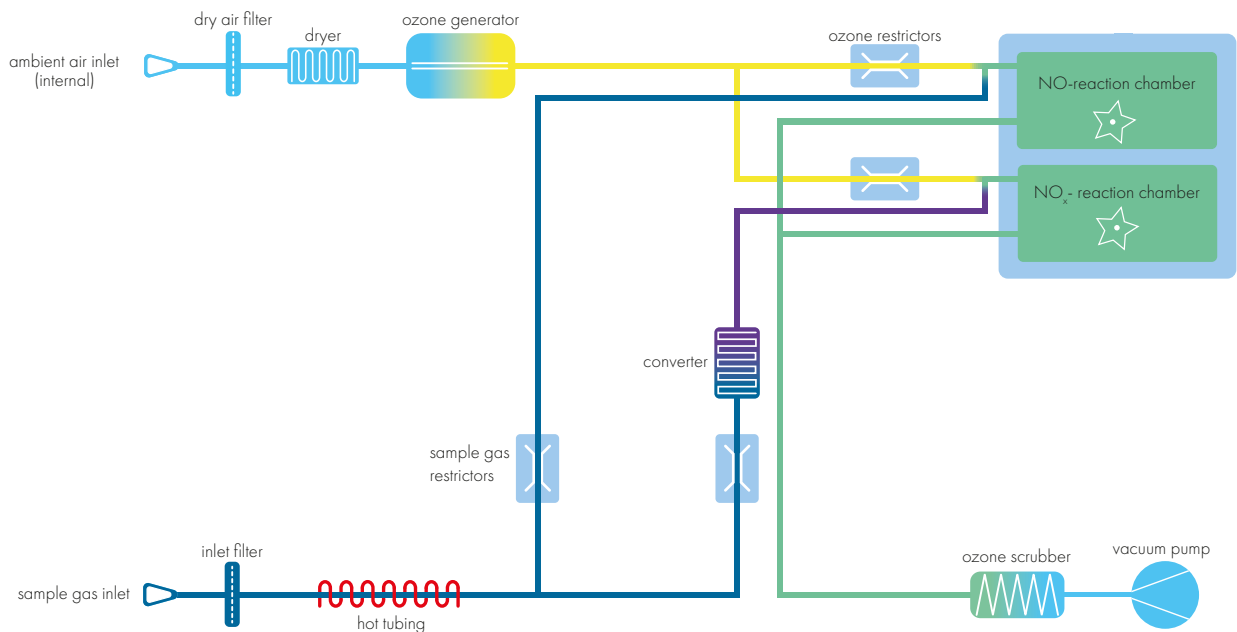

ECO PHYSICS

ECO PHYSICS AG · POB · CH-8635 DUERNTEN · TEL. +41 55 220 22 22 · E-MAIL INFO@ECOPHYSICS.COM

WWW.ECOPHYSICS.COM